

## DS-D41Q15CA-1PH-UHK

P1.53, 320 mm × 160 mm, Indoor LED



- Supports seamless image stitching in any direction, size and shape and displays stitched images uniformly and consistently without black lines
- Screen Frame Rate: 60 Hz refresh
- Pixel LED Type: SMD RGB (3-in-1)
- Uses the ultra-high refresh rate to display delicate and smooth video images
- Uses the broadcast grayscale processing to show more image details
- High brightness and high contrast
- Material Composition: Engineered plastic with glass fiber reinforcement, aluminum housing with back cover (optional)
- Scan Type and Drive System: 1/8 Scan with Constant Current Drive System
- Light Intensity Control: 100-step dimming
- Fault Rate: Equal to or below 0.00001
- Operational Lifetime (50% Brightness): 100,000 hours
- Mean Time Between Failures: Over 6,000 hours
- Pixel Gap:  $\leq 0.2\text{mm}$  between each pixel

## ▪ Specification

Model		DS-D41Q15CA-1PH
<b>Product Model</b>	Product Model	DS-D41Q15CA-1PH-UHK
<b>Module</b>	Pixel Configuration	SMD
	Pixel Pitch	1.538 mm
	Lamp Bead Dimensions	1212
	Dimensions of Module	320 mm × 160 mm
	Module Resolution	208 × 104
	Pixel Density	422500
	Signal Source Interface	HUB320
<b>Display</b>	White Balance Brightness	≥ 600 nits
	Color Temperature	3000K to 10000K adjustable
	Viewing Angle	160° (H)/160° (V)
	Brightness Uniformity	≥ 97%
	Color Uniformity	≤ ± 0.003Cx, Cy
	Contrast Ratio	6000:1
	Refresh Rate	3840 Hz
<b>Processing Performance</b>	Scanning Amount	52
	Grey Level / Colors	Up to 32 bits
<b>Power</b>	Max. Consumption	≤ 600 W/m <sup>2</sup>
	Average Consumption	< 290 W/m <sup>2</sup>
	Input Voltage	DC: 4.5 V to 5 V (Leakage to Ground: Less than 1mA)
<b>General</b>	Package Dimensions (W × H × D)	673 (W) mm × 248 (H) mm × 390 (D) mm (26.50" × 9.76" × 15.35") (20 cabinets in 1 box)
	Packing List	Several high magnetic brackets Several LED lamp beads and IC components Several signal cables and power cables
	Gross Weight	0.55 kg (1.21 lb)
	Net Weight	0.48 kg (1.06 lb)
	<b>Working Environment</b>	Working Temperature
	Working Humidity	10% RH to 90% RH (without condensation)
	Storage Temperature	-20 °C to 60 °C (-4 °F to 140 °F)
	Storage Humidity	10% RH to 95% RH (without condensation)
	Ingress Protection	IP67
	Certification	CE, FCC, ROHS, EMC

▪ **Available Model**

DS-D41Q15CA-1PH-UHK

▪ **Dimension**

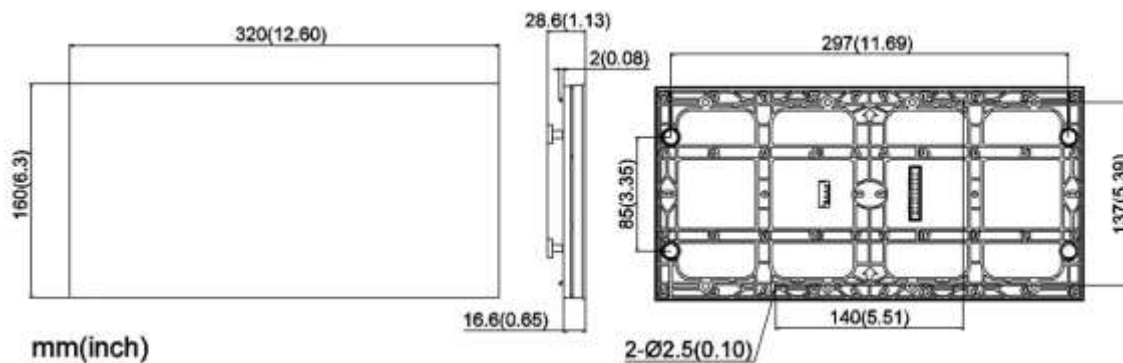

**Headquarters**

No.555 Qianmo Road, Binjiang District,  
Hangzhou 310051, China  
T +86-571-8807-5988  
www.hikvision.com



Follow us on social media to get the latest product and solution information.

